

Maintenance Free - High Capacity Dual Purpose AGM Batteries



Model: **HC120**

BCI Group: 6T



HIGH RATE DISCHARGE @ 77° (25°C) - STARTING

5 Seconds	10 Seconds	20 Seconds	30 Seconds
2250 Amps	2045 Amps	1725 Amps	1620 Amps

EXTENDED DISCHARGE @ 77° (25°C) to 10.02V- DEEP CYCLE

5 Min	15 Min	1 Hour	3 Hour	5 Hour	10 Hour	20 Hour
422 Amps	208 Amps	75 Amps	31.2 Amps	20.7 Amps	11.5 Amps	6.25 Amps

PERFORMANCE FEATURES

- PHCA: 2250A at 80°F (27°C) for 5 seconds
- PCCA: 1420A at 0°F (-18°C) for 5 seconds
- CCA: 1150A at 0°F (-18°C)
- CA/MCA: 1450A at 32°F (0°C)
- HCA: 1700A at 80°F (27°C)
- 120 AH @ 20 Hr Rate
- Reserve capacity: 273 minutes
- Short circuit current: 5000A
- Operation temperature range: -22°F (-30°C) to 122°F (50°C)

BATTERY DESIGN

- 12V VRLA **Starting/Deep Cycle** Battery
- Absorbed Glass Mat (AGM) technology
- Sealed Construction (Non-Spillable Battery)
- Can be mounted in any orientation except inverted
- US DOT, IMDG, ICAO and IATA certified non-spillable
- Can be fitted with brass automotive terminal
- Durability - withstands shock and vibration
- Available with metal casing for high heat applications

NOMINAL DIMENSIONS

Length		Width		Height		Total Height		Weight	
mm	inch	mm	inch	mm	inch	mm	inch	kg	pound
284	11.181	268	10.55	205.5	8.091	225	8.858	38.7	85.32

SIZE & DETAILED ILLUSTRATION

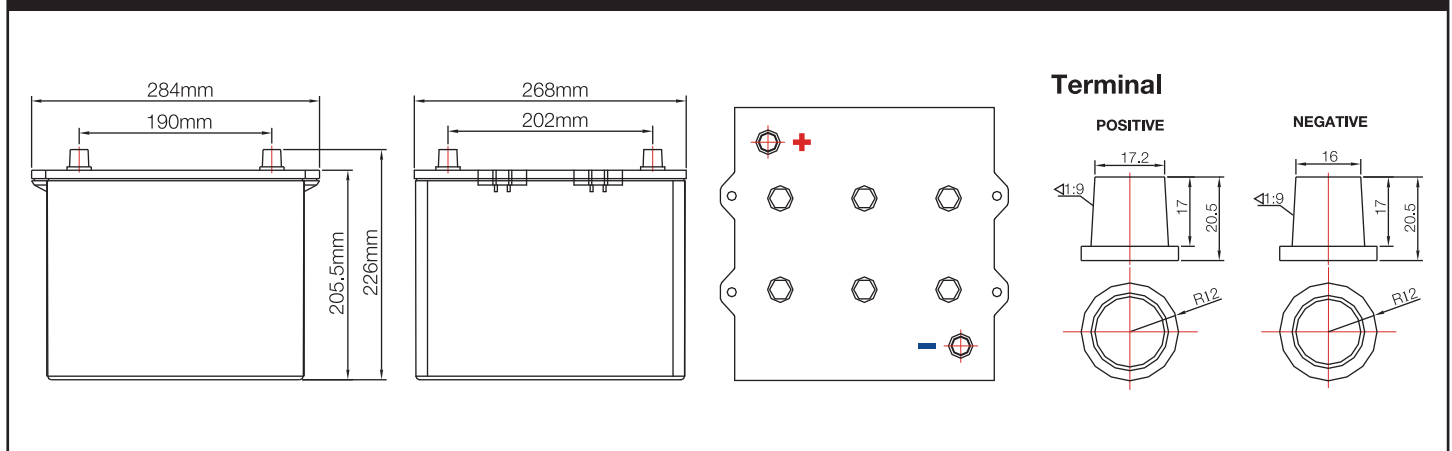

This information is generally descriptive only and is not intended to make or imply any representation, guarantee or warranty with respect to any cells and batteries. Cell and battery designs/specifications are subject to modifications without notice. Contact Fullriver for the latest information.